

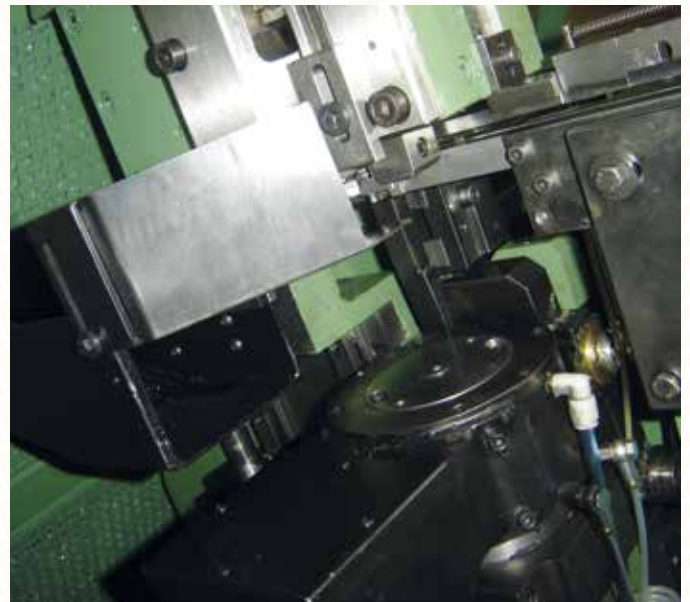

# Chamfering machines for production of points and special pieces

## SM2

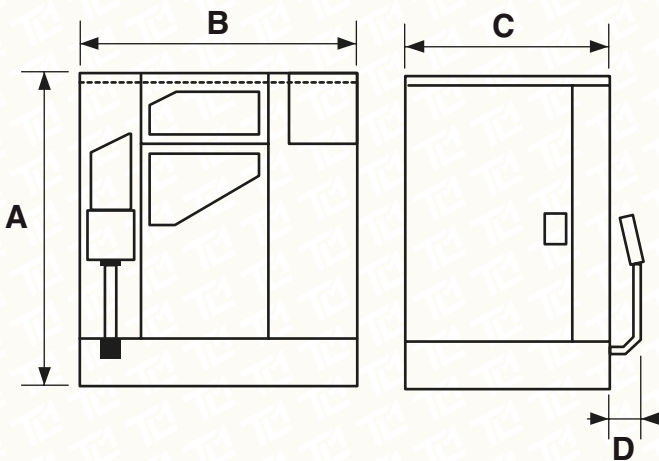

**Technical features: approximate values.** The machine speed can change according to the material used and the type of item to be rolled. Measures in mm.

| Output capacity | Diameter of screw | Min. Length | Max. Length | Machine sizes including the system for total soundproofing |
|-----------------|-------------------|-------------|-------------|--|
| 250/265         | 5 - 8             | 16          | 82          | A 2380 - B 1525 - C 1270 - D 234                           |