

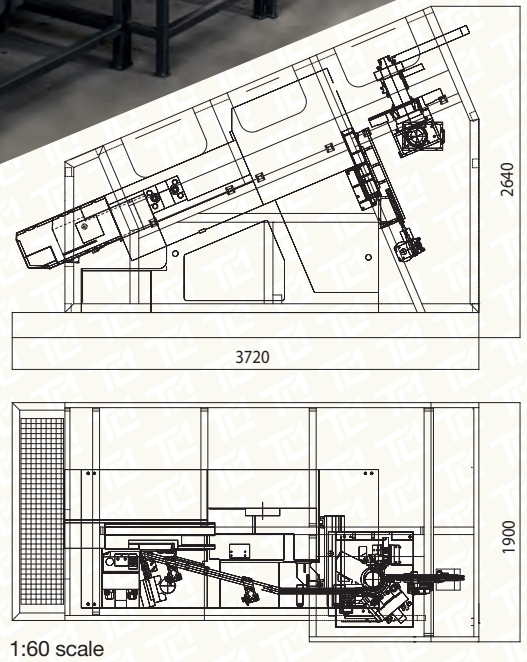

Flat dies machine + roll and segment rolling machine + load lift

RP/RS16 MF + LB900

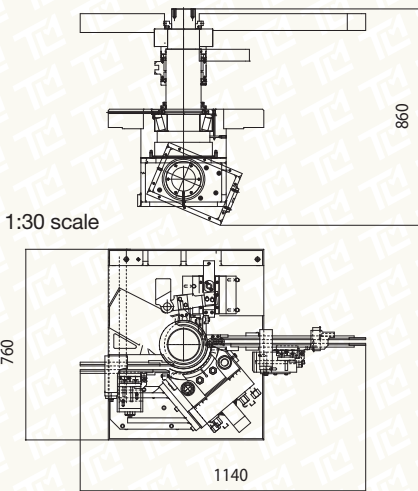

Technical features: approximate values. The machine speed can change according to the material used and the type of item to be rolled. Measures in mm.

Roll and segment rolling machine RS16

Output capacity	Screw diameter	Thread length	Max length of shank underhead	Standard tools size	Special tools size	Total motors power	Net weight approx	Machine sizes
min 70 max 500	min 6 max 16	min 20 max 100	150	roll Ø 127 sector Ø 340 H 100	on request	HP 20	Kg 4000	A 760 - B 1140 H 860

Flat dies machine RP16/S

Output capacity	Screw diameter	Thread length	Max length of shank underhead	Standard tools size	Special tools size	Total motors power	Net weight approx	Machine size without soundproof hood
min 60 max 160	min 8 max 16	min 20 max 120	140 / 180	228,6 x 254 x 42,8 H130	on request	HP 25	Kg 6300	A 1500 - B 3500 H 1950